



Installation/Owner Manual

SOLVELOX Glycol System

S-SV-G100

Table of Contents

INTRODUCTION	1
System Overview	1
SolVelox Glycol Advantage	1
Safety	1
Materials List	2
Installation	3
Sizing the Collectors	3
Collector Orientation	3
Flush Mount Installation	4
Connect to Pipes	6
Pipe Runs	6
Check Collector Loop for Leaks	8
Charging the System	8
Start Up the System	8
Maintenance	10
Appendix:	11
WATTS Series 70A Installation Instructions	14
Warranty	15
SolVelox Glycol	15

INTRODUCTION

System Overview

A solar thermal glycol system can provide 70-90% of your domestic hot water needs annually. Heat transfer fluid is run through a solar collector and heated by the sun. The heat is then transferred to the potable water in your hot water tank. The heat transfer fluid and the potable water are circulated through each "loop" by a high efficiency circulation pump through a brazed plate heat exchanger. The heat transfer fluid has a very low freezing point which keeps your collectors safe from freeze damage. The pumps are controlled by a differential control which reads the temperatures at the collector and in the tank. It provides power to the pumps when the temperature in the collectors is 14° higher than the tank water.

SolVelox Glycol Advantage

SOLARHOT has uniquely created the SolVelox package which pre-assembles and integrates an oversized stainless steel heat exchanger along with the pumps and valves necessary to drive a two-loop solar system. The heat exchanger and pumps are sized to meet the heat output of up to 6 solar flat panel solar collectors so one SolVelox appliance provides an economical solution as you scale the solar system to meet your particular needs. Also, the SolVelox is externally mounted in order to reduce maintenance issues.

Safety

The best performance will come from a solar collector with aluminum sides and low iron solar glass well sealed to hold the heat. These materials weigh 80-150 lbs depending on the size of the collector. Use extreme caution when mounting collectors on a roof or when connecting any wiring or electrical hookups.

- ALWAYS use fall protection
- Secure all ladders on level ground
- Locate all possible hazards, overhead wires, loose shingles etc
- Make sure power is turned off before adding water to the system
- NEVER hookup power to the water heater or storage tank until it has been filled.
- Use a tempering valve or mixing valve to prevent scalding
- Consult proper authorities and check with your local building inspector for permit requirements and local building codes before project commencement. System must meet local code requirements for penetrating structural members and fire-rate assemblies.



Certification

The solar energy system described by this manual, when properly installed and maintained, meets the minimum standards established by the SRCC. This certification does not imply endorsement or warranty of this product by SRCC.

Materials List

Included in the box:

- 1 SolVelox
- 1 SolVelox bracket
- 1 Expansion Tank Bracket
- 1 18" Stainless Steel flexible pipe
- 1 24" Stainless Steel flexible pipe
- 4 Screws for mounting the SolVelox
- 1 Differential Control
- 2 Sensors
- 50 ft Sensor Wire



You will also need:

- electric water heater
- expansion tank
- SRCC certified collectors with mounting hardware
- 3/4" copper pipes
- 1" elastomeric insulation eg. Nomaco K-Flex LS
- PVC insulation jacketing eg Speedline Smoke Free PVC
- vinyl tape
- 1 - 3/4" coolie hat roof flashing
- 1 - 3/4" coolie hat roof flashing with gooseneck
- 2 - 1' unions
- 2 - 1" caps
- 2 - 1" to 1/2" elbows
- 40% propylene glycol heat transfer solution
- Watts 70A tempering valve



Installation

Sizing the Collectors

Sizing the collector area: The maximum energy you can get out of the system is controlled by a few things and the square footage of collectors on the roof (or in the yard) is one of them. The more square footage of collectors you have the more potential you have for collecting solar energy. If you live in the southern half of the country, the rule of thumb says you need 20 sq. ft. of collector area for the first two people in the household and 8 sq. ft. of collector area for each person after the first two. If the home is in the northern U.S. you would want to install 20 sq. ft. of collector area for the first two people and 14 sq. ft. per person for additional people.

This rule of thumb doesn't take into consideration the quality of the solar collector that you use. It is possible to have a solar collector that produces 2/3rd of the energy because the absorber is painted black –vs.- using a selective coating or because it uses lower quality glass that doesn't allow as much light to pass through. The rule of thumb that I just mentioned is appropriate for high quality solar collectors. I am defining a high quality solar collector as having either black chrome plated absorber or having some form of selective surface. Also, the glazing (glass) on the collector needs to be high transmission tempered glass. Avoid plastic glazed collectors since the clarity of the plastic will degrade quickly over time and ruin the value of your investment.

For more precise calculations based on weather data and collector information there are software packages available such as RETScreen available on the internet. <http://www.etscreen.net>

Collector Orientation



The collectors should be mounted as close to due south as reasonable considering the roof line, however, if the collector is mounted within 55 degrees of south any performance drop is insignificant. The aesthetics of flush mounting a collector on the roof will generally outweigh performance improvements less than 5%.

The collectors should ideally be inclined at the same angle as the latitude, i.e. if you are located in Raleigh, NC (latitude 38 degrees) you would ideally have the collectors inclined 38° from horizontal. Testing has shown that mounting a collector within $\pm 15^\circ$ of the site's latitude will lead

to no significant degradation in the collector's performance.

Pay close attention to the angle and direction of the roofline. If your roofline doesn't match the ideal criteria listed above, we recommend adding collector area as opposed to tilt mounting the collector. For example: If your roof faces the southeast, you may use three collectors instead of the two collectors which would be typical for a family of 4.

Further, minimize the shade over the collectors. Collector should receive 6-8 hours of direct sunlight each day for optimal performance.

Flush Mount Installation

Locate a Rafter

Unfortunately there are no stud finders for rooftops but it is important to mount the collectors into the rafters. Here are a couple of ideas for how to locate a rafter:

- From inside the attic, drill an angled hole from the intersection of the roof deck and the rafter at a 45° angle into the roof deck from the intersection. Where the drill first penetrates the roof should be approximately the center of the rafter.
- From the attic measure the distance from an existing roof protrusion (such as a vent or chimney) to the nearest rafter. Use that same measurement on the outside of the roof
- Drill from the outside of the roof. Measure from the attic side of the hole to the nearest rafter. Use the same dimensions of the outside.



Installing the Mounting Brackets

- Mark a 10 foot long horizontal line at least 10" below the peak of the roof.
- Measure 97 ½" down from the first horizontal line and mark another 10' line.
- Locate the center of a rafter and mark vertically along the rafter with a chalk line between the two horizontal lines.
- Using the rafter spacing make vertical marks over the center of the rafters marking all the rafters that the collectors will span.
- Using the mounting foot as a template, hold the mounting foot at the center of each intersection. Holding the foot at the intersection of the chalk lines, mark the holes with a marker. Repeat this procedure until each of the mounting foot locations have been marked. (4 mounting feet for each collector)
- With a 3/16" drill, Drill a pilot hole at each one of the marks you just made.
- Fill each pilot hole with roofing caulk using a caulk gun.
- Apply roofing tar to the underside of each mounting foot.
- Place the mounting feet over the pilot holes. Screw the brackets to the rafters using 3/8" x 3" stainless steel lag screws, flat washers and lock washers.

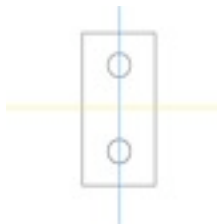

Preparing the Collectors

While still on the ground, you should solder on the 1 in couplings that will join the collectors. Note that the collectors have a sticker that says "This Side Up". The sticker side should be closest to the roof peak as there are weep holes to release condensation on the other side. Be careful of the orientation when you solder on the couplings so that they will join together when the collectors are mounted side by side. The two open ends of the collectors will have street elbows soldered to the inlet and outlet of the collectors and 1" caps onto the 2 other corners.

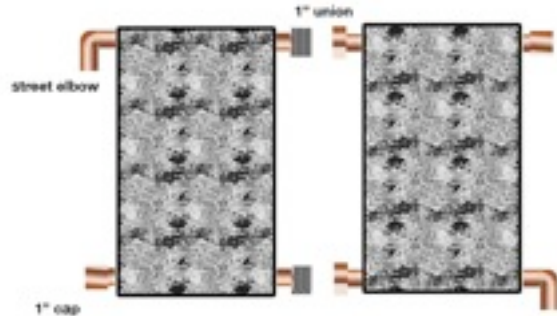

Mounting the Collectors

- Build scaffolding, nail two by fours to stand on and wear fall protection.

Collectors each have their own mounting systems but many of them are similar. The following mounting system works for SOLARHOT and many other collectors brands:

- The mounting clip is made up of two parts joined by a stainless steel bolt with lock washer. Before taking the collectors up to the roof, slide the stainless steel sliding nut into the anodized aluminum channel foot. Now carefully place the first collector so that the mounting clip fits in the mounting groove that runs around the bottom edge of the collector and tighten the bolt. NOTE: Each collector uses different clips, ensure that you have the correct mounting clips for your collector.
- Mount the next collector so that the unions join to the first collector and secure the mounting clips.
- Wrap male union threads with plumbing tape, connect and tighten the union couplings.

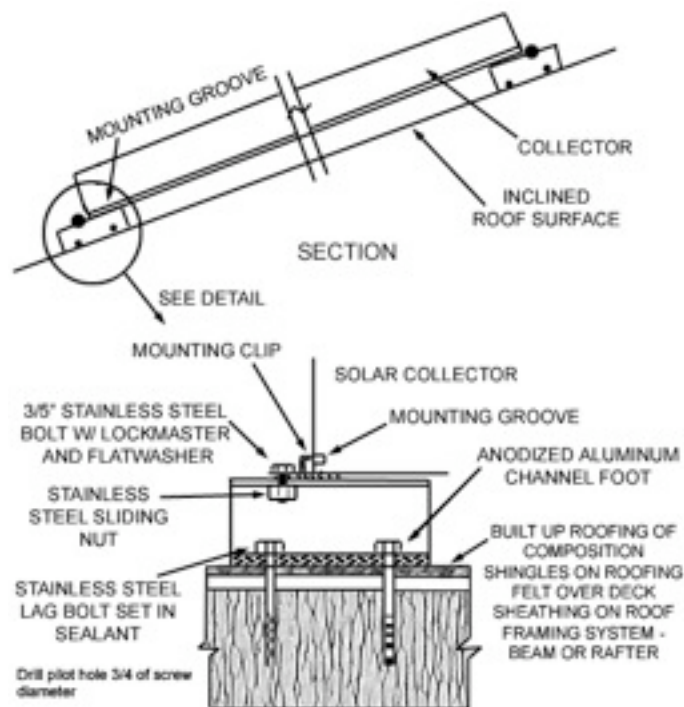

Connect to Pipes



- Using a wood bit the same size as your pipes, drill a hole in the center of a shingle below where the bottom corner of the collector will be and in the opposite corner where the collector outlet will be.
- Apply sealant to the underside of the copper flashing. Carefully raise the drilled shingle, place flashing underneath and insert collar through the hole.
- Run pipes from attic through the coolie hat and sweat connect them to the street elbows.
- Strap the PT1000 probe sensor to the copper pipe at the collector outlet using a stainless steel screw clamp. Feed the sensor wire through the gooseneck of the coolie hat. The coolie hat can then be

soldered to seal it from leaks. All the copper from the coolie hat to the collector needs to be covered with insulation and UV jacketing. The sensor must be isolated from exterior conditions.

Pipe Runs

Use 1/2" copper pipes on the collector loop. All pipes should be wrapped with at least 3/4" thick insulation. We recommend 1" Elastomeric insulation. Outdoor pipes should also be jacketed with UV protection material or some other means to protect it from moisture and ultraviolet deterioration. We recommend Nomaco K-Flex LS with Speedline Smoke Safe PVC Fitting Covers and vinyl tape.

All pipes must be well supported or they will sag. Hanger should spread the load so that the insulation is not compressed. Place supports every 4.7 feet.

Refer to the following diagram for the relative location of the pipes, collectors and SolVelox. The cold water supply line to the solar storage tank must be covered with a minimum of 7/8" x 1/2" insulation for 5 feet from the water heater.

Please note that if the water storage tanks are located in or above living spaces a drip pan with a drain line to the outside of the building is required.

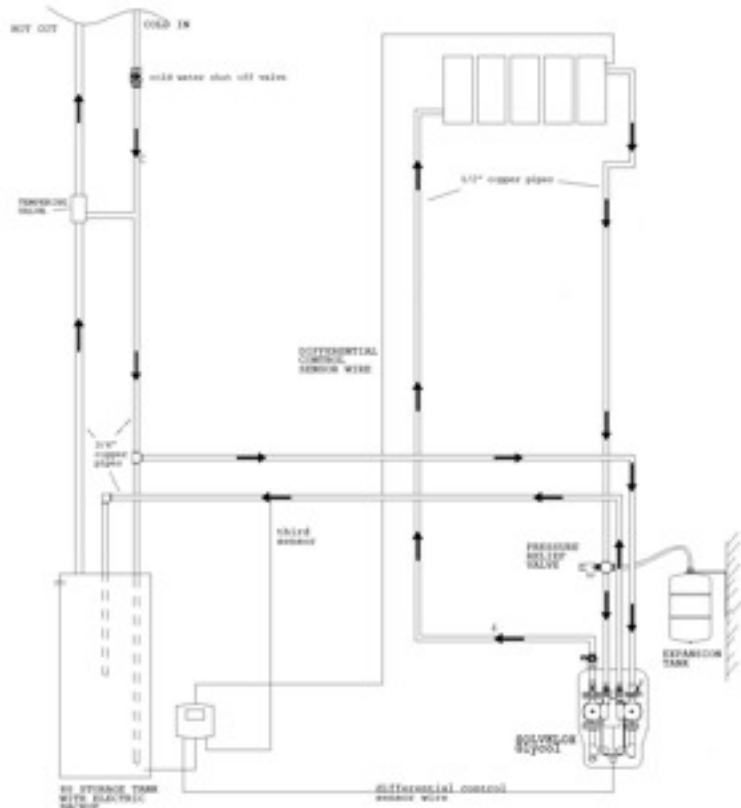

Mounting SolVelox onto the Tank

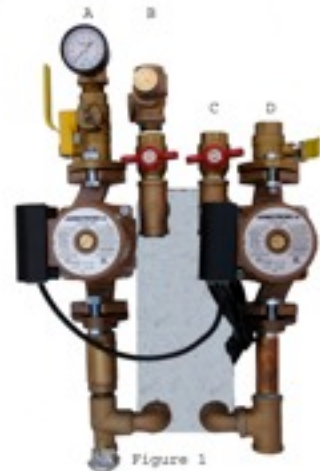
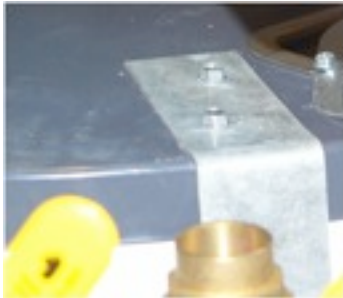

- Confirm that the P&T valve is on the side of the tank. If it is on the top of the tank, unscrew it and place it in the port on the side of the tank.
- Use needle nose pliers to remove the heat trap from the hot side of the tank and set aside.
- Feed the solar dip tube into the tank, closed end down, until it seats below the threads of the tank top fitting.
- Lay the tank down on the ground on top of cardboard or towels.
- Remove the white paper backing and stick the solid piece of Elastomeric insulation included in the SolVelox package to the back of the heat exchanger..
- Place the bracket over the SolVelox and place the assembly on the side of the tank. The side of the SolVelox should be 1 inch to the left of the top electrode cover. The bracket should lie flat on the top of the tank. Scribe the tank to match the bracket location.
- Using two #10 - 16 x 3/4" self drilling screws, screw the top of the bracket to the top of the hot water tank. Ensure that the vertical section of the bracket above the heat exchanger is flush with the side of the tank before you drive in the screws.
- While holding the bracket and the SolVelox firmly against the tank, drive two #10-16 x 3/4" self drilling screws into the lower section of the bracket just below the heat exchanger. It is critical that you hold the bracket and SolVelox firmly against the tank at this point otherwise it will be loose when you stand the tank upright. Seek assistance to make sure you get the product snug on the tank.
- Connect a 3/4" brass tee to the cold water inlet to the tank.
- Using 3/4" copper pipe and fittings or 3/4" MxF flexible stainless steel pipe, join the ball valve D of the SolVelox assembly (refer to Figure 1) with the Tee connected to the cold inlet. This is the cold water input to the SolVelox.
- Using 3/4" pipe and fittings or 3/4" MxF flexible stainless steel pipe, connect the hot water inlet (where you perviously installed the solar dip tube) to ball valve C on the SolVelox. This is the hot water return to storage.
- The differential control is in the cover of the SolVelox. The SolVelox comes with 50 ft of 18 gauge sensor wire, if you require more wire than that, use UV stable (black) 18 gauge sensor wire. Place a sensor against the lower part of the interior tank by removing the lower access panel. While the panel is open, lower the bottom heating element to it lowest set point.
- Attach the expansion tank using the flexible stainless steel tubing to the port on the above the second ball valve from the left. Mount the expansion tank to the wall or to the storage tank.
- Remove the white backing from the insulation provided and insulate the heat exchanger.
- The ports A and B on the left are for the collector loop. The pipe coming from the top of the collectors, bring the hot antifreeze solution from the collectors attaches to port B. The pipe leading to the collector attaches to port A directly above the pressure gauge.

Check Collector Loop for Leaks

- Open all shut off valves on collector loop before system has been charged.
- Attach a female to male adapter to the drain valve on the bottom left of the SolVelox.
- Open drain valve and attach gas test block with pressure gauge.
- Apply 60 psi pressure for 15 minutes. Any drop in pressure during that time indicates a leak.
- Find the source of the leak and repair it. Repeat this procedure until the loop holds pressure.



Charging the System

- Connect the outlet of a 1HP pump via a hose to the fill valve
- Open fill valve located below the pressure gauge on port A.
- Open the boiler drain valve located on the bottom left corner of the SolVelox. (below the pump which leads to port A)
- Connect boiler drain to a bucket
- Fill the bucket with the appropriate mixture of propylene glycol and water. (see manufacturer's recommendation on the percentage of propylene glycol necessary for freeze protection in your area- we recommend Noble NoBurst)
- Run pump - initially air will vent out of the boiler drain, then a mixture of coolant and air will follow. This process may take 10-30 minutes.
- Continue running the pump until you do not see air bubbles in the coolant.
- Turn off pump. Let the system sit for 2 minutes. Repeat previous steps until no air is discharged.
- Close boiler drain.
- Keep charging until it reaches the necessary pressure for the system's configuration. The system requires 15 psi plus 1 psi per 2.3 vertical feet to the top of the collector.
- Close the fill valve.
- Turn off and disconnect charging pump.

Start Up the System

- Confirm that all shut off valves are fully open.
- Turn on system and let it run for 5 minutes.
- Double-check every component, pipe runs and fittings for leaks.

Check System Operation

- Add 3rd Steca sensor to the control
- Strap the sensor to the pipe returning to the tank as far from the tank as possible using a stainless steel screw clamp. (port C on the SolVelox)
- Insulate over the sensor.
- Let the system run for 15 minutes on a sunny day preferable around noon. 3 temperatures will show on the control. The collector outlet temperature, the bottom of the tank temperature and temperature of the water returning to the tank. Typically you should see the temperature at the bottom of the tank vary from 60 -80° F (city water temperature) to 185° (high limit set on the control) The water at the top of the tank will be typically higher than the water at the bottom but should not exceed the high limit set on the control. The Temperature and Pressure Relief Valve is set to 210° F.
- The system will automatically turn on the pumps when the collector temperature is 16° higher than the water at the bottom of the tank. It will then shut off the system when the temperature differential is 6° F. Collector temperatures may rise well above 200° F but the system will not run beyond the high limit set on the control.

- A system correctly installed will show the water returning to the tank to be at least a 3-10° F warmer than the water at the bottom of the tank.

Operations

Your SolVelox Glycol system is automated by the Steca control located on the face of the cover. Please refer to the Steca manual for system operation or adjustments.

Vacation and Emergency Shut Off

If the system is not to be used for any extended period of time, the differential control should be set to HOLIDAY function.

To set the STECA control to HOLIDAY function:

- Open the menu settings by pressing the SET button for approximately 2 seconds.
- Press the DOWN button until the holiday symbol (umbrella) flashes.
- Press the SET button for approximately 2 seconds until the small tick on the holiday symbol appears.

To resume operations:

- Open the menu settings by pressing the SET button for approximately 2 seconds.
- Press the DOWN button until the holiday symbol (umbrella) flashes.
- Press the SET button for approximately 2 seconds until the small tick on the holiday symbol disappears.

See the STECA control manual for more details about the HOLIDAY function.

If there is a leak or other issue requiring the collector loop to be drained, turn the system off by setting the switch on the left side of the Steca control to the OFF position. Attach a hose to the drain valve on the lower left of the SolVelox. Open the drain valve. Exercise extreme caution as the heat transfer fluid (HTF) may be dangerously hot. Do NOT dispose of the HTF on the ground or in the water system. Collect the HTF in a container which can be sealed and dispose of it according to the manufacturer's directions.

Maintenance

Your solar water system requires very little by way of maintenance but a few regular system checks can extend the life of your system well beyond 20 years.

Freeze Protection

This system is designed to protect itself from freeze damage to temperatures as low as -30°F as long as the heat transfer fluid in the collectors is at least 40% propylene glycol (Noble NoBurst). Freeze tolerance limits are based upon an assumed set of environmental conditions. In the event of extreme or prolonged cold weather, protect your system by shutting down the system and draining the collector loop as described in the section "Vacation and Emergency Shut Off".

Clear sediment from 40 mesh strainer

- Turn off your solar water system and disconnect the power to the SolVelox by unplugging the Steca control from the wall outlet.
- Close the 2 ball valves on the right side (ports C & D) of the SolVelox.
- Open the clean out port.
- Remove any sediment build up from the clean out port.
- Close and tighten clean out port
- Return shut off flanges to the open position and reconnect the power to the SolVelox

Descaling the heat exchanger

- Turn off your solar water system and disconnect the power to the SolVelox by unplugging the Steca control from the wall outlet.
- Close the 2 shut off valves on the right side of the SolVelox (ports C & D).
- Unscrew the plugs to open the descaling port and the clean out port.
- Remove any sediment build up from the clean out port.
- Flush the heat exchanger with a weak solution of white vinegar and water.
- Close and tighten descaling and clean out port
- Return shut off flanges to the open position and reconnect the power to the SolVelox



Change Heat Transfer Fluid

The heat exchange fluid (such as Noble NoBurst HD) contains buffers which keep the pH of the solution neutral. Heat and time will degrade these buffers so it is important that you drain the fluid and recharge the system every 3-5 years. To drain the system, turn the system off by setting the switch on the left side of the Steca control to the OFF position. Attach a hose to the drain valve on the lower left of the SolVelox. Open the drain valve. Exercise extreme caution as the heat transfer fluid may be dangerously hot. Dispose of used heat transfer fluid according to manufacturer's directions.

Appendix:

Congratulations on the installation of your SOLARHOT SOLVELOX Glycol System. Correctly installed and maintained, your system should provide you with many years of uninterrupted solar hot water. The solar collectors are designed to last 25-35 years, electric water heaters 10-20, pumps, controls and valves 5-10. Local water quality and usage will greatly affect life expectancies.

Component Guide

SolVelox by SOLARHOT featuring Armstrong Astro30B and Astro20B pumps, 12"x 5" 10 plate heat exchanger, 3/4" Isolation Flanges. Fill weight 25 lbs, rated for 220° F and 120 psi.

Steca Differential Control TR 0301U, requires PT1000 probe or lug replacement sensors

Sensor Wire - Genesis 22/2S shielded sensor wire

American Premier 80 gallon electric water heater - E62-80H-045DV fill weight 855lbs, certified at 300psi test pressure and 150 psi working pressure and 210°F

SRCC certified collectors -SOLARHOT S-SC-126P32 fill weight 122lbs, test pressure 160 psi

3/4" coolie hat roof flashing with and without gooseneck

Watts 70A tempering valve

24" M x F flexible stainless steel pipes

Propylene glycol solution - Noble NoBurst

Elastomeric insulation - Nomaco K-Flex LS

UV jacketing - Speedline Smoke Safe PVC Fitting Covers

Kaori K70 10 plate heat exchanger

MATERIAL SAFETY DATA SHEET

NOBURST® -100

1. General

Date Prepared: May 2, 2000

Trade Name NOBURST -100

Manufacturer's Name THE NOBLE COMPANY

Address 7300 Enterprise Drive Spring Lake, MI 49456

Emergency Telephone Number (231) 799-8000

Telephone Number for Information (231) 799-8000

Synonyms None

Chemical Family Glycols

Generic Name Monopropylene Glycol

DOT Hazardous Material Proper Shipping Name Not regulated;

DOT Hazard Class; DOT Packing Group; DOT Reportable Quantity (Based on Material); UN/NA ID No. ;Not regulated orNot applicable

CAS No. (See Section 9 — Components) MSDS Class F

2. Summary of Hazards

Signal Word CAUTION

Physical Hazards Aqueous solutions may produce flammable vapors; Slightly combustible liquid

Acute Health Effects (Short-Term): No inhalation hazard identified from data available; Slight eye irritant; No ingestion hazard identified from data available; No skin irritation hazard identified from data available; No skin absorption hazard identified from data available

Chronic Health Effects (Long-Term) : No chronic health hazards are expected to occur from anticipated conditions of normal use of this material

3. Fire and Explosion

Flash Point: AP 2280 F (PMCC)

Autoignition Temperature: AP 700° F

Flammable Limits (at Normal Atmospheric Temp and Pressure): Lower: AP 2.4 (% vol in air) Upper: AP 17.4 (% vol in air)

Fire and Explosion Heat Hazards from fire can generate flammable vapor. When mixed with air and exposed to ignition source, vapors can burn in open or explode if confined. Vapors may travel long distances along the ground before igniting and flashing back to vapor source. Fine sprays mists may be combustible at temperatures below normal flash point. Aqueous solutions containing less than 95% propylene glycol by weight have no flash point as obtained by standard test methods. However aqueous solutions of propylene glycol greater than 22% by weight, if heated sufficiently, will produce flammable vapors. Always drain and flush systems containing propylene glycol with water before welding or other maintenance.

Extinguishing Media: Alcohol type foam; CO2; Dry chemical

Extinguishing Media Use waterspray/waterfog for cooling

Special Firefighting Procedures: Do not enter fire area without proper protection. Fight fire from a safe distance/protected location. Heat may build enough pressure to rupture closed containers/spreading fire/increasing risk of burns/injuries. Use water spray/fog for cooling. Avoid frothing/steam explosion. Burning liquid may float on water. Although water-soluble, may not be practical to extinguish fire by water dilution. Notify authorities immediately if liquid enters sewer/public waters.

4. Health Hazards

Summary of Acute Hazards: Not expected to present a significant acute health hazard upon short-term exposure.

Inhalation No significant signs or symptoms indicative of any adverse health hazard are expected to occur as a result of inhalation exposure.

Eye Contact May cause minor eye irritation.

Skin Absorption No significant signs or symptoms indicative of any health hazard are expected to occur as a result of skin absorption exposure.

Skin Irritation No significant signs or symptoms indicative of any adverse health hazard are expected to occur as a result of skin exposure.

Ingestion No significant signs or symptoms indicative of any health hazard are expected to occur as a result of ingestion.

Summary of Chronic Hazards No adverse chronic health effects are expected from anticipated conditions of normal use of this material unless aerosol is generated.

Special Health Effects This material or its emissions may aggravate pre-existing eye disease.

5. Protective Equipment and Other Control Measures

Respiratory No special respiratory protection is recommended under anticipated conditions of normal use with adequate ventilation.

Eye Eye protection such as chemical splash goggles and/or face shield must be worn when possibility exists for eye contact due to splashing or spraying liquid, airborne particles, or vapor. Contact lenses must be worn.

Skin Not normally considered a skin hazard. Where use can result in skin contact, practice good personal hygiene. Wash hands and other exposed areas with mild soap and water before eating, drinking, smoking, and when leaving work.

Engineering Controls No special ventilation is recommended under anticipated conditions of normal use beyond that needed for normal comfort control.

Other Hygienic Practices Use good personal hygiene practices. Wash hands before eating, drinking, smoking, or using toilet facilities. Promptly remove soiled clothing/wash thoroughly before reuse. Shower after work using plenty of soap and water.

Other Work Practices No special work practices are needed beyond the above recommendations under anticipated conditions of normal use.

6. Occupational Exposure Limits

No occupational exposure limit(s) have been established for this material or its components

7. Emergency and First Aid

Inhalation Not expected to present a significant inhalation hazard under anticipated conditions of normal use.

Eye Contact In case of eye contact, immediately rinse with clean water for 20-30 minutes. Retract eyelids often. Obtain emergency medical attention if pain, blinking, tears or redness persists.

Skin - Contact Not expected to present a significant skin hazard under anticipated conditions of normal use.

Ingestion Not expected to present a significant ingestion hazard under anticipated conditions of normal use.

Physician's Emergency Medical Treatment Procedures Treat symptomatically. Treatment of overexposure should be directed at the control of symptoms and the clinical condition of the patient. After adequate first aid, no further treatment is required unless symptoms reappear.

Physician's Detoxification Procedures No detoxification information available.

8. Spill and Disposal

Precautions if Material is Spilled or Released

May contaminate water supplies/pollute public waters. Evacuate/limit access. Equip responders with proper protection. Prevent flow to sewer/public waters. Stop release. Notify fire and environmental authorities. Restrict water use for cleanup. Slippery walking. Spread granular cover. Impound/recover large land spill. Soak up small spills with inert solids. Use suitable disposal containers. On water, material is soluble and may float or sink. May biodegrade. Contain/collect rapidly to minimize dispersion. Disperse residue to reduce aquatic harm. Report per regulatory requirements.

Waste Disposal Methods

Landfill solids at permitted sites. Use registered transporters. Burn concentrated liquids, diluting with clean, low viscosity fuel. Avoid flameouts. Assure emissions comply with applicable regulations. Dilute aqueous waste may biodegrade. Avoid overloading/ poisoning plant biomass. Assure effluent complies with applicable regulations. Contaminated product, soil, water, container residues and spill cleanup materials should not be designated as hazardous wastes.

9. Components

Propylene Glycol 57-55-6 N/P

Dipotassium Phosphate 7758-11-4 N/P

##1=U.S. National Toxicological Program 2=International Agency for Research on Cancer 3=U.S. Occupational Health and Safety Administration 4=American Conference of Governmental Industrial Hygienists 9=Other N/P=No Applicable Information Found

10. Component Health Hazards

Propylene Glycol Slight eye irritant

11. Additional Toxicological Information

Propylene Glycol

High concentrations of Propylene Glycol in water when held in contact with human skin under closed conditions have been reported to cause skin irritation (Cosmetics and Toiletries 99:83-91, 1984). The authors attribute the observations to a sweat retention reaction by skin. No reactions were observed in open patch tests with human subjects. One literature report indicates rare eczematous skin reactions and even more rarely an allergic skin reaction from exposure to Propylene Glycol (Anderson and Starr, Hautzart 33 (1) 1982).

Material: No additional toxicology information is available for this material.

12. Physical and Chemical Data

Boiling Point: AP 370° F (at 760 mm Hg) Viscosity: AP 46 CPS (at 770F) (Brookfield) Dry Point: AP 374°F

Freezing Point AP > -50°F Vapor Pressure AP 0 mm Hg (at 68° F) Volatile Characteristics Slight

Specific Gravity: AP 1.04 (H₂O=1.0 at 39.2° F) Vapor Specific Gravity: AP 2.6 (Air =1.0 at 60-90° F) Solubility in Water: Complete (In All Proportions)

pH: 9 Hazardous Polymerization: Not Expected to Occure Stability: Stable

Other Chemical Reactivity: Reacts with strong oxidizing agents

Other Physical and Chemical Properties: Hygroscopic

Appearance and Odor Pink; Slightly viscous liquid; Little or no odor

Conditions to Avoid: High temperatures, oxidizing conditions

Materials to Avoid: Strong oxidizing agents

Hazardous Decomposition Products: Incomplete combustion may produce carbon monoxide and other toxic gases

13. Hazards Rating Information

National Fire Protection Association Health = 0 Flammability = 1 Reactivity = 0 Special Hazard — None

Ratings have been based on available component information from the National Fire Protection Association.

National Paint and Coatings Association: Hazardous Material Information System (HMIS): Health = 0 Flammability = 1 Reactivity = 0

Ratings have been generated according to criteria specified in the National Paint and Coatings Association Implementation Manual based on component information available.

14. Additional Precautions

Handling and Storage Procedures Hygroscopic. Use dry nitrogen or low dew point air for tank padding. Keep drums tightly closed to prevent contamination. Store at 65-90o F.

Decontamination Procedures: Isolate, vent, drain, wash and purge systems or equipment before maintenance or repair. Wear recommended personal protective equipment. Observe precautions pertaining to confined space entry.

15. Regulatory Information

Federal: The following is the Toxic Substances Control Act (TSCA) Chemical Substance Inventory Status of the components of this material listed in Section 9 –Components:

Propylene Glycol 57-55-6 Listed –Non Confidential

Dipotassium Phosphate 7758-11-4 Listed - Non Confidential

Superfund Amendments and Reauthorization of 1988 (SARA), Title III

-Section 302/304

Requires emergency planning based on ‘Threshold Planning Quantities’ (TPOs), and release reporting based on Reportable Quantities (RQs) of ‘Extremely Hazardous Substances’ (EHS) listed in Appendix A of 40 CFR 355. There are no components of this material with known CAS numbers which are on the EHS list.

-Section 311 & 312

Based upon available information, this material and/or components are not classified as any of the specific health and/or physical hazards defined by Section 311 & 312.

-Section 313

The material does not contain any chemical components with known CAS numbers that exceed the De Minimis reporting levels established by SARA Title III, Section 313 and 40 CFR 372. Comprehensive Environmental Response, Compensation and Liability Act (CERCLA) No chemicals in this material with known CAS numbers are subject to the reporting requirements of CERCLA.

OSHA Regulations ‘Chemical-specific’ U.S. Occupational Safety and Health Administration (OSHA) regulations (1910.1002 to 1910.1050) presented under 29 U.S. Code of Federal Regulations (CFR) 1910 do not apply to this material or its components.

Other EPA Regulations No additional information available

Department of Transportation (DOT) Other than the normal shipping instructions and information given in this MSDS, there is no other specific U.S. Department of Transportation (DOT) regulations governing the shipment of this material.

State Regulations:

California Safe Drinking Water and Toxic Enforcement Act of 1988 –Proposition 65. This material is not known to contain any chemicals currently listed as carcinogens or reproductive toxins under California Proposition 65 at levels which would be subject to the proposition. California South Coast Air Quality Management District (SCAQMD) Rule 443.1 (VOC’s) A Volatile Organic Compound (VOC) is any volatile compound of carbon excluding methane, carbon monoxide, carbonic acid, metallic carbides or carbonates, ammonium carbonate, 1,1,1-trichloroethane, methylene chloride, (FC-23), (CFC-113), (CFC-12), (CFC-11), (CFC-22), (CFC-114), and (CFC-115). By this definition, this is a VOC material.

Massachusetts Right to Know Substance List (MSL) [105 CMR 670.000]

Extraordinarily Hazardous Substances (MSL-EHS) must be identified when present in materials at levels greater than state specified criterion. The criterion is $\geq 0.0001\%$. Hazardous Substances (MSL-HS) on the MSL must be identified when present in materials at greater than the state specified criterion. The criterion is $\geq 1\%$. Components with CAS numbers present in this material, at levels specified in Section 9 –Components, do not require reporting under the statute.

New Jersey Registration

The New Jersey, Registry 3, Registration law does not apply to this material, as none of its components are trade secrets.

Pennsylvania Right to Know Hazardous Substance List

Hazardous Substances (PA-HS) must be identified when present in materials at levels greater than the state specified criterion. The criterion is $\geq 1\%$. Components with CAS numbers in this material at a level which could require reporting under the statute are:

Propylene Glycol 57-55-6

Dipotassium Phosphate 7758-11-4

Special Hazardous Substances (PA-SHS) must be identified when present in materials at levels greater than the state specified criterion. The criterion is $\geq 0.01\%$. Environmental Hazards (PA-EH) must be identified when present in material at levels greater than the state specified criterion. The criterion is $\geq 0.01\%$. Components with CAS numbers in this material, at levels specified in Section 9 –Components, do not require reporting under the statute.

Regulatory Advisory

If you reformulate or further process this material, you should consider re-evaluation of the regulatory status of the components listed in this sheet.

16. General Comments

This document is generated for the purpose of distributing health, safety, and environmental data. It is not a specification sheet nor should any displayed data be construed as a specification.

DISCLAIMER OF LIABILITY:

The information in this MSDS was obtained from sources which we believe are reliable. However, the information is provided without any warranty, express or implied, regarding its correctness. The conditions or methods of handling, storage, use or disposal of the material are beyond our control and may be beyond our knowledge. For this and other reasons, we do not assume responsibility and expressly disclaim liability for loss, damage or expense arising out of or in any way connected with the handling, storage, use or disposal of the material.

This MSDS was prepared and is to be used only for this material. If the material is used as a component in another material, this MSDS information may not be applicable. This document is generated for the purpose of distributing health, safety, and environmental data. It is not a specification sheet nor should any displayed data be construed as a specification. Some of the information presented and conclusions drawn herein are from sources other than direct test data on the material itself.

THE INFORMATION PRESENTED HEREIN, WHILE NOT GUARANTEED, WAS PREPARED BY TECHNICALLY KNOWLEDGEABLE PERSONNEL AND TO THE BEST OF OUR KNOWLEDGE IS TRUE AND ACCURATE. IT IS NOT INTENDED TO BE ALL-INCLUSIVE, AND THE MANNER AND CONDITIONS OF USE AND HANDLING MAY INVOLVE OTHER OR ADDITIONAL CONSIDERATIONS. CONSULT THE NOBLE COMPANY FOR FURTHER INFORMATION.

WATTS Series 70A Installation Instructions

Hot Water Extender Tempering Valves

IMPORTANT: Inquire with governing authorities for local installation requirements.

INSTALLATION

(Valve should be installed by a licensed contractor.)

1. Close both the hot and cold water shutoff valves upstream of the valve.
2. Bleed pressure from the system.
3. Remove the thermostat and bonnet assembly (A), which is hand-tight, from body and install valve body as illustrated in diagram. Valve must be trapped as shown.
4. Reinsert Thermostat and Bonnet assembly in body and tighten knurled portion of bonnet securely with pliers or channel locks.
5. **START UP REQUIREMENTS:** Open cold water then hot water shutoff valves. The cold water supply line to Series 70A valve should always be opened first to prevent possible thermostat damage.

ADJUSTMENT

The Series 70A features a new adjustment means which permits you to “dial” a temperature quickly and conveniently. To increase or decrease the water temperature, simply turn the adjusting cap as indicated by the arrow. The adjustment temperature range is 120°F to 160°F and will vary depending on system water pressure changes and water temperature fluctuations.

CAUTION: Need for Periodic Inspection

Periodic inspection by a licensed contractor is recommended. Corrosive water conditions, temperatures over 210°F, unauthorized adjustments or repair could render the valve ineffective for service intended. Regular cleaning and checking of thermostat assembly (A) helps to assure maximum life and proper product function. Frequency of cleaning depends upon local water conditions.

† WARNING

Do not use Watts Series 70A Hot Water Extender Tempering Valves to temper water at fixtures. Severe bodily injury, i.e., scalding or chilling, and/or death may result, depending upon system water pressure changes and/or supply water temperature changes. ASSE standard 1016 listed devices such as Watts MMV, L111 and USG-B valves should be used at fixtures to prevent possible injury.

The Watts Hot Water Tempering Valves are designed to be installed at or near the boiler or water heater. They are not designed to compensate for system pressure and/or temperature fluctuations and should not be used where ASSE 1016 devices are required. These Watts Valves should never be used to provide “anti-scald” or “anti-chill” service.

IMPORTANT: BE SURE TO REMOVE THERMOSTATIC ASSEMBLY

from valve before sweating connections, otherwise it will become damaged.

Minimum Flow Requirements to
Maintain Set Temperature: 2 gpm
for size ½" and ¾"

Warranty

SolVelox Glycol

Limited 2 year Warranty

SolarH2Ot Limited warrants to Buyer for a period of twenty-four (24) months from the date of sale that the equipment at the time of shipment will be free from defects of design, material and workmanship. If any defects or mal-performance occur during the warranty period, SOLARHOT's obligation shall be limited to alteration, repair or replacement at SOLARHOT's expense, F.O.B. Factory, of parts or equipment, which upon return to SOLARHOT and upon SOLARHOT's examination prove to be defective. Equipment and accessories not manufactured by SOLARHOT are warranted only to the extent of and by the original manufacturers' warranty. SOLARHOT shall not be liable for damage or wear to equipment caused by abnormal conditions, acts of God, failure to properly prime or to operate equipment without flow or caused by corrosives, abrasives or foreign objects. THE FOREGOING WARRANTY IS EXCLUSIVE AND IN LIEU OF ALL OTHER WARRANTIES, WHETHER EXPRESSED OR IMPLIED INCLUDING ANY WARRANTY OF MERCHANTABILITY OR FITNESS FOR ANY PARTICULAR PURPOSE. In no event shall SOLARHOT be liable for consequential or incidental damages.

Service

To obtain service for your SolVelox™, notify the dealer who installed or sold the SolVelox™. In notifying your dealer, provide identification of your SolVelox™, date of purchase (with proof) and the nature of the defect. Ship the SolVelox™ complete in the assembled condition. Use adequate packaging to prevent damage to the pump during shipment. To obtain the location of the nearest authorized SOLARHOT service and/or distribution facility, call 1-919-439-2387 or write to: **SOLARH₂OT Ltd.**, 233 East Johnson St Suite O Cary, NC 27513; or on the web at <http://www.solarhotusa.com>; email: customersupport@solarh2ot.com.